

DALI MCU digital rotary dimmer

09.2400RA.04756



Important: Read All Instructions Prior to Installation

Function introduction

Rotate the knob counterclockwise to decrease light intensity from 100% to 1%.

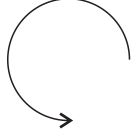

Rotate the knob clockwise to increase light intensity from 1% to 100%

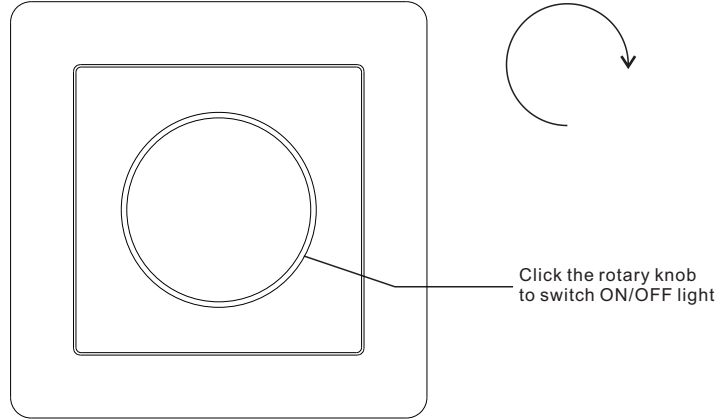
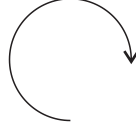

Front side

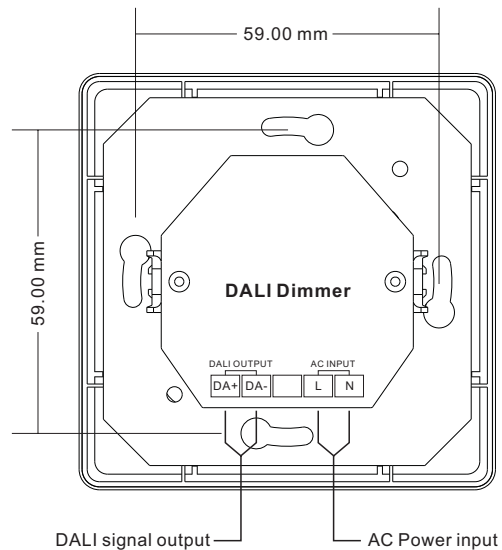
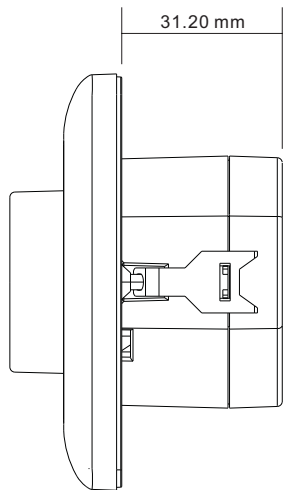

Back side

Product Data

Designation	DALI MCU
Power connection	L, N AC mains
Operating voaltage	100-240V AC
Power consumption	2.3W max.
DALI connection	DA+/DA-, max. 300m cable length, DALI power supply output current max 100mA.
Perm. Cable cross-section	0.5... 1.5 mm ²
Ambient temperature	0...+50 °C
Type of protection	IP 20
Protection class	II
Dimensions	80x80x53mm

Each control circuit can supply DALI power for as many as 50 DALI devices
The lighting system responds immediately and harmoniously when the brightness level is changed at either of the control devices.

All that while allowing for the required comfortable, easy and complete control over the lighting levels at any time.

Innovative Function to Power DALI Bus While Connected to AC Mains
Powered by DALI Bus while not Connected to AC Mains

Safety & Warnings

- DO NOT install with power applied to device.
- DO NOT expose the device to moisture.

Operation

This device is a DALI MCU with built-in DALI bus power supply which can power DALI bus while connected with 100-240VAC mains. It also can be powered by DALI bus while not connected with AC mains.

There can be up to only 2 MCUs connect to AC 220V mains, the other MCUs powered by DALI bus.

Each control circuit simultaneously affords the integration of as many as 50 DALI ECG and of up to 4 DALI MCU control devices (control points).

Switch ON/OFF

Click the rotary knob to switch ON/OFF light.

Increase/Decrease Light Intensity

Rotate the knob clockwise to increase light intensity from 0% to 100%, rotate the knob counterclockwise to decrease light intensity from 100% to 0%.

Set the minimum brightness value

Press and hold down the knob over 5 seconds until the light flashes, to set the current brightness value as the minimum brightness value for dimming, it is dimmable from this minimum brightness value to 100%.

Delete the minimum brightness value setting

Click the knob to switch off the light first, then press and hold down the knob over 5 seconds until the light flashes, the minimum brightness value will be deleted. It is dimmable from 0% to 100% then.

Installation

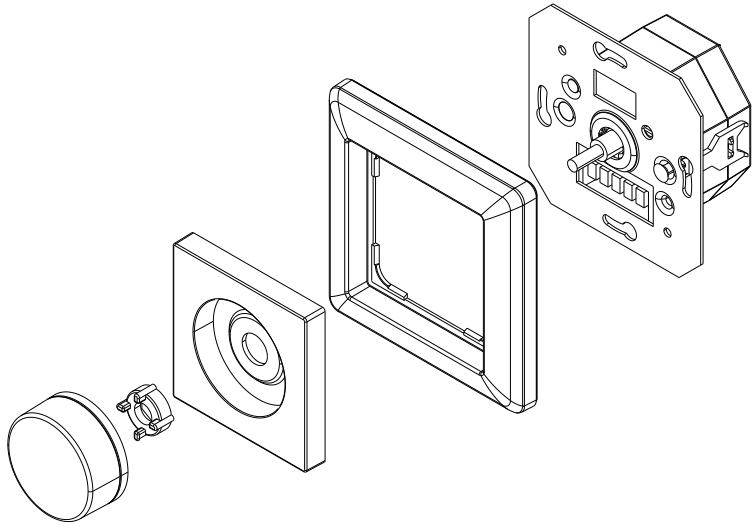

Wiring diagram

Figure 1: Wiring scheme to control up to 50 DALI ECG

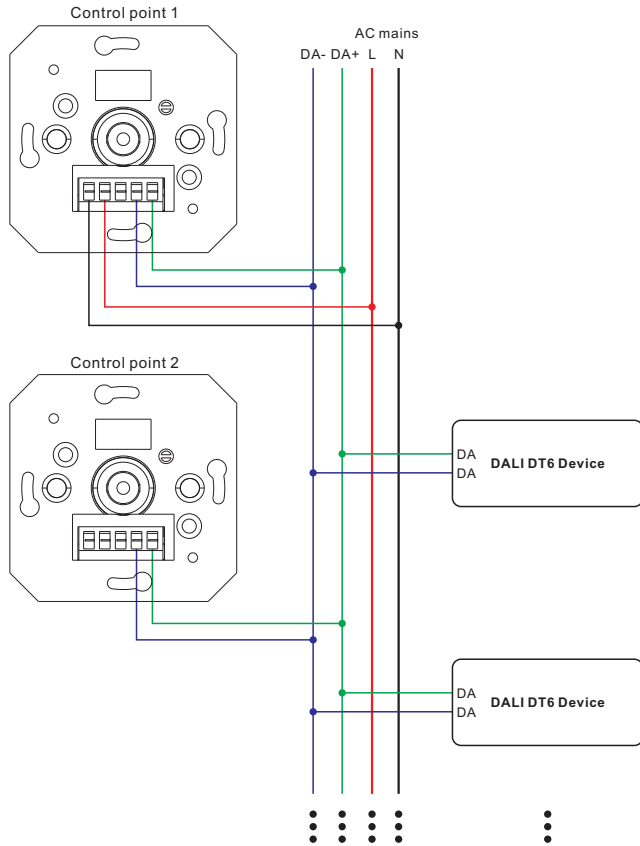
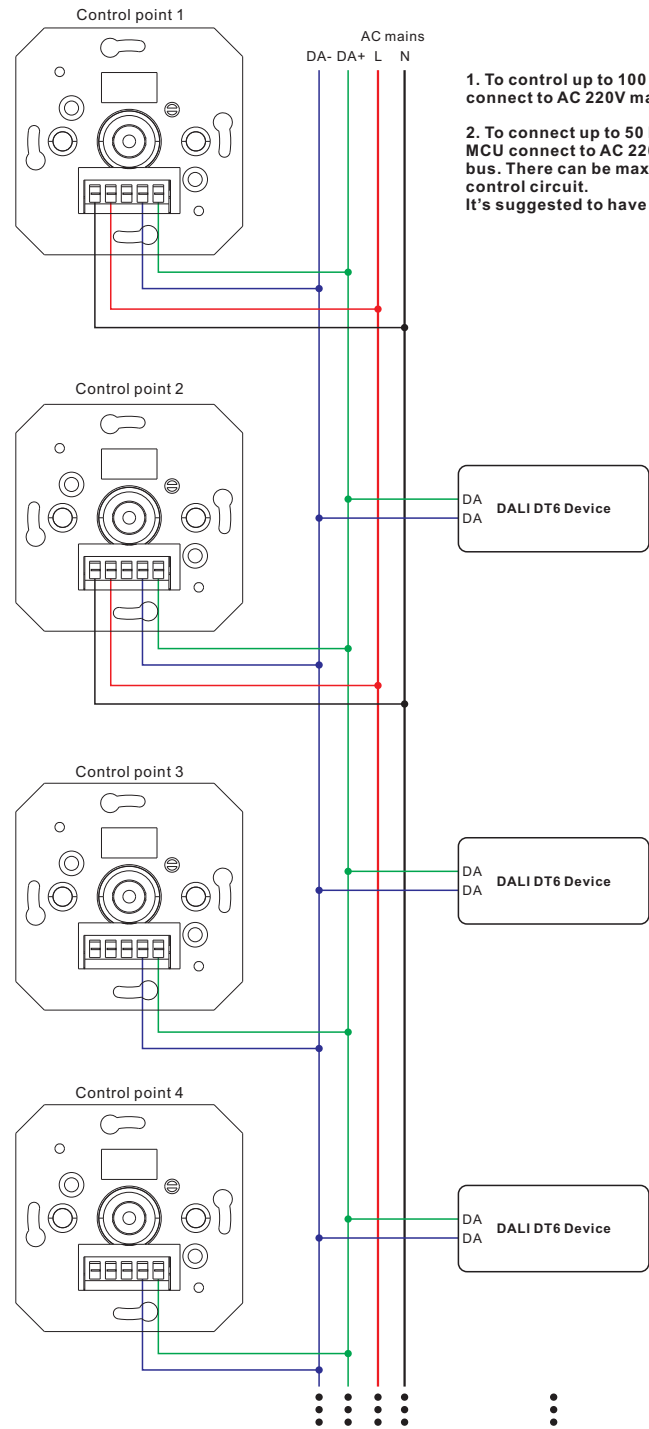

Figure 1: Wiring scheme with 2 MCUs powered by AC mains to control up to 100 DALI ECG



1. To control up to 100 ECG with the setup(Figure 2), there is 2 MCUs connect to AC 220V mains.

2. To connect up to 50 ECG with the setup(Figure 1), there is only 1 MCU connect to AC 220V mains, the other MCUs powered by DALI bus. There can be max 2 MCUs connected to the AC mains in the same control circuit. It's suggested to have max 4 MCUs totally in the same control circuit.